



11640017 Sideways Drum Rotator – Handle

The 11640017 Sideways Drum Rotator is designed to lift and rotate 205 litre Drums through 360° perpendicular to the fork arms. Handle rotation via a Gearbox of the drum cradle ensures minimum effort for fully controlled tipping, allowing complete emptying of the drum contents. A Chain Belly Strap with an eccentric lock holds the Drum firmly in position. This slip-on attachment requires only the connection of a safety chain to a narrow carriage Forklift. The standard finish of this unit is painted enamel.

SPECIFICATIONS:

- » Safe Working Load (SWL) 500kg
- » Unit Weight 110kg
- » 360° Rotation
- » Load Centre 1385mm
- » Pocket Size 165 x 65mm
- » Pocket Centres 375mm
- » Horizontal C of G 600mm

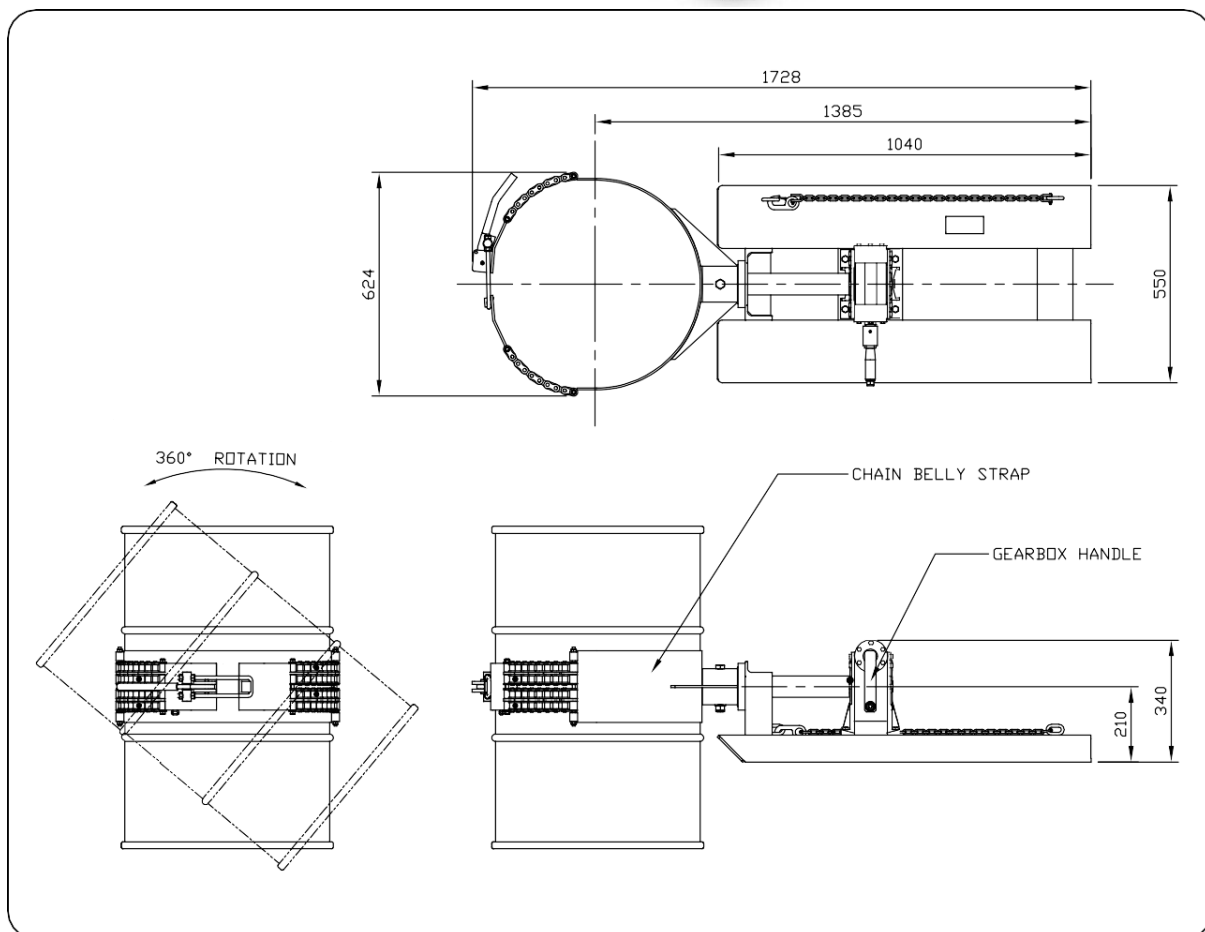
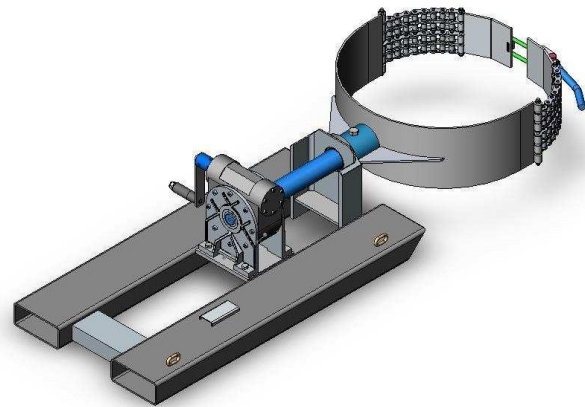

SPECIFICATIONS SUBJECT TO CHANGE WITHOUT NOTICE